

# Solar Powered Brushless DC Motor Drive with Z-Source Inverter for Water Pumping System

(E. D. Vinodhkumar)<sup>1</sup> (M. Murali)<sup>2</sup>

M.Tech (Student)<sup>1</sup> (Associate Professor)<sup>2</sup>

Electrical and Electronics Engineering (EEE)

VEMU Institute of Technology

**Mail Id:** (Edvinodhkumar1993@gmail.com)<sup>1</sup> (Murali.epe@gmail.com)<sup>2</sup>

## Abstract:-

This study describes a solar PV system for pumping systems that maximises solar energy while also providing a soft start for BLDC motors. The model will ensure that a variety of parameter effects on the PV array are investigated in conjunction with the operative temperature and solar irradiation level. This research entails a level of analysis of the electrical phenomena system's real-time interpretation, as well as issues such as temperature and irradiation. The BLDC motor's speed is controlled from start to finish by the electrical converter.

**Keywords**— Array, BLDC Motor, Converter, Pump.

## I.INTRODUCTION:-

Sunlight based energy is amazingly elite type of sustainable energy sources which has acquirement expanding consideration in advanced year. The power generation from sun oriented source is continuously spotless; free from contamination besides a twist in nature because of that sun based source is for the most part utilized wherever, where it gives most extreme advantages from source. In ongoing year, the cost of sun powered PV board is going downwards which increment consideration regarding use sunlight based PV application in futuristic year. Sustainable power sources based application utilized as a part of ventures what's more, main residence application. Among all other application based sun oriented PV framework, water pumping is best, significant and financially crucial

application for control generation by Solar PV array. For water pumping framework for the most part induction engine, dc engine are utilized as a part of rural and additionally framework associated region for induction engine. For pumping load, basic, minimal effort and effective engine is for the most part utilized.

Fundamentally to pump area, acceptance engine is for the most part favored it is effortlessly accessible in showcase moreover gives great exhibitions for any heap condition however when acceptance engine is favored for sun oriented PV based application, it experiences overheating phenomena of engine , if voltage of engine will low, because of that it require a complicated control. Under low voltage condition, proficient, dependable and financially savvy engine must be utilized. In this way, The BLDC engine is

utilized for such application. The brushless DC engine is perfect decision for application that requires high unwavering quality, high proficiency and capacity to volume proportion. By and large, a BLDC engine is well thoroughly considered to be a high show engine that is capable of giving colossal measures of torque in excess of a huge speed extend. For Solar PV based application, BLDC engine is without a doubt contend with some other engine for drawing application as it gives predominant execution of engine alongside delicate beginning. BLDC engine is progression of the greater part of the DC engine and they have nearly same torque and

speed regular bend uniqueness .The key variety between two is the utilization of brushes. BLDC engine for pumping framework strategy alongside sun oriented PV source, both mix builds its utilization and unwavering quality. Greatest profits by sunlight based PV, is acquired by utilizing most extreme power point following (MPPT) algorithm. For MPPT following, for the most part P &O, incremental conductance algorithm is utilized.

Among that incremental conductance gives best execution under quickly changing air condition, anyway it indicates poor execution at low irradiance level utilizing the DC- DC converters. This paper expand thought for appropriate utilization of Sunlight based PV based application and delicate beginning of BLDC engine. For greatest advantage from sun based PV array, boost converter is utilized and switch of boost converter is worked through incremental conductance MPPT algorithm. The accompanying proposed framework gives benefits of sunlight based PV based application driven by BLDC engine for water pump as appeared in fig.1. There are different approaches to control speed of BLDC engine like hysteresis control and other control plot are utilized. Be that as it may following design is straightforward, ease, commotion free and having slightest part of the framework; make arrangement is reasonable for water pumping framework.

## II.PROPOSED SCHEME:-

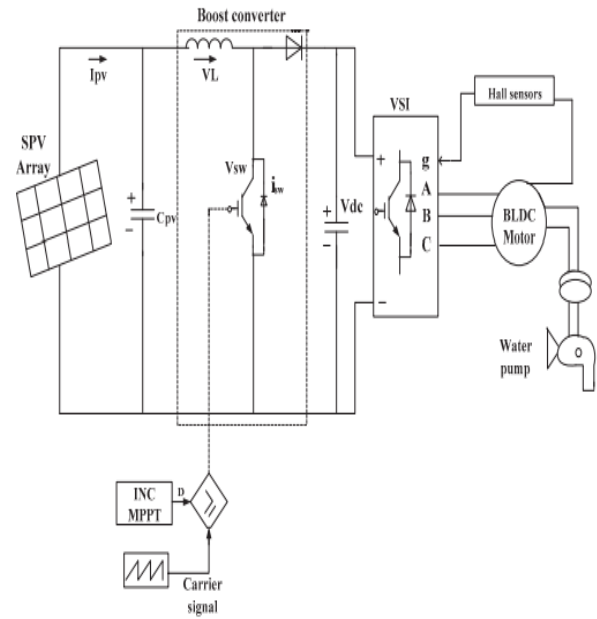


Fig.1. Configuration of the SPV array fed BLDC motor driven water pumping system.

## III.PROPOSED SYSTEM CONFIGURATION AND OPERATING PRINCIPLE:-

Fig.1 demonstrates the proposed framework setup, in which BLDC engine is utilized for pumping framework , BLDC engine is worked by voltage source inverter of DC-link.the proposed framework gives energy from sun based PV based boost converter for pumping load. Sun based PV array creates energy provides for the boost converter; the switch of the boost converter is worked by MPPT algorithm with the end goal that most extreme benefits from sunlight based PV array is enhanced and furthermore gives smooth execution of BLDC engine for pumping application. The corridor sensors are utilized as a part of request to detect rotor position of engine. Hall sensors are electronically drove circuit utilized for inverter exchanging.

## IV.DESIGN OF THE PROPOSED SYSTEM:-

The differed working strides of the arrangement appeared in Fig.1 for example the SPV array, the boost converter along with the water pump are planned to such an extent that a sensible capacity is constantly capable below some kind of change in sunlight based insolation level. A BLDC engine of 1.3 kW appraised control is favored alongside each

phase of the proposed framework are consider in like manner as take after.

### A. Design of Solar PV Array:-

A SPV array of 1.5 kW top power limits is favored in such approach that the elucidation of the plan isn't influenced by the misfortunes associated amidst the converters. The parameters of the SPV array are evaluated at the standard sun based seclusion level of 1000 2 @/m .As irradiance esteem transforms it influences power and therefore effectiveness of the framework is get influenced, accordingly proficiency of the framework is diminished.

### Maximum Power Point Tracking (MPPT) Controller:-

The MPPT capability is by and large used to change a greatest benefit that is most extreme productivity in sun oriented PV planted application. In this paper, incremental conductance MPPT controller is utilized which gives smooth and optimizing Execution under any air condition. This MPPT gives preferred execution over P and o algorithm. The INC conductance MPPT is followed by means of assessing existing conductance with next incremental conductance. From incremental conductance flowchart [8], current and voltage are yield of sun powered PV array whenever. The obligation cycle of boost converter assume critical part keeping in mind the end goal to gets most extreme profits by sun based PV array. At the point when sun oriented PV voltage wind up steady after specific point, yield current is going to expands, at that point obligation proportion is likewise moved forward. On the off chance that present decreases at that point obligation proportion falls. In by and large, primary motivation behind algorithm is to look towards the fitting obligation cycle in which incremental conductance getting to be quick conductance because of that PV framework is constantly worked around MPP.  $\Delta D$  is incremental size which decides how quick MPP is going to followed, grater measure  $\Delta D$  optimizing will be accomplish. The real benefits of incremental conductance are that it can produce predominant outcomes below rapidly evolving condition.

### C. Design of Boost Converter:-

By and large boost converter is utilized to work framework at higher voltage level. Legitimate outline of converter helps for appropriate use of the framework. As because of the main switch of boost converter had greatly superb redesign productivity.

Boost converter decides most extreme power from sunlight based PV array.

Voltage of SPV array at maximum point is

$$V_{pv} \cong 248.5V,$$

as source of input voltage, and  $V_{dc}$  is dc output voltage of boost converter, the input-output relationship of boost converter as shown in equation (1).

$$D = \frac{V_{dc}}{V_{dc} + V_{pv}} = \frac{311}{311 + 248.5} = 0.55 \quad (1)$$

Where  $V_{dc}$  is DC voltage of inverter and PV I is calculated as according to equation (2).

$$I_{dc} = \frac{P_{mpp}}{V_{dc}} = \frac{1500}{311} = 4.98A \quad (2)$$

As summation of the two current dc I and pv I flow through circuit, inductor L is estimated as according to equation (3).

$$L = \frac{D * V_{pv}}{f_{sw} * \Delta I_L} = \frac{0.55 * 248.5}{10000 * 11 * 0.4} = 3mH \quad (3)$$

Where  $F_{sw}$  is switching frequency of the boost converter and  $\Delta I_L$  is a ripple content in the inductor.

### D.Hall sensors signals:-

In BLDC engine, to detect rotor position, for the most part corridor sensors are utilized, which figures out which winding will be invigorated in the following succession. Hall signals produced by the inbuilt encoder of the engine as per the situation of rotor. Corridor sensors for the most part put in stator to detect rotor position.

As indicated by the pointed area of the rotor position, the encoder produces three Hall Effect signals. These Hall Effect signals are intelligently changed into six exchanging beats drawn to deal with the six IGBT switches of The VSI as appeared in table I.

Table .ISwitching states for electronic commutation Of BLDC motor

$\theta$	Hall signals			Switching states					
	H1	H2	H3	S1	S2	S3	S4	S5	S6
Degree									
NA	0	0	0	0	0	0	0	0	0
0-60	0	0	1	0	0	0	1	1	0
60-120	0	1	0	0	1	1	0	0	0
120-180	0	1	1	0	1	0	0	1	0
180-240	1	0	0	1	0	0	0	0	1
240-300	1	0	1	1	0	0	1	0	0
300-360	1	1	0	0	0	1	0	0	1
NA	1	1	1	0	0	0	0	0	0

### E. Design of Water Pump:-

Load torque of water pump algorithm and design is given as,

$$T_L = \frac{K_p}{\omega^2} \quad (4)$$

$$k_p = 3.24 * 10^{-5} \frac{Nm}{rad/s^2}$$

$\omega_m$  = rotational speed in rad/sec

$T_L$  = Load torque offered by pump(Nm)

$K_p$  = constant for selected water pump

For pumping load, divergent pump is utilized as it is basic, straightforward and utilized for a large portion of the application reason. Claim to fame of radial Pump gives fast exhibitions with having minimum support, because of that for pumping load, divergent pump is picked. As it gives, the yield of engine is smooth dynamic, consistent alongside enduring yield.

### V. DESIGNING OF THE PROPOSED SYSTEM USING Z-SOURCE INVERTER

The proposed framework setup, wherein BLDC engine is applied for pumping framework, BLDC engine is labored by using Z-supply inverter of DC-interface. The proposed framework offers energy from sun powered PV based totally lift converter for pumping load. Sunlight primarily based PV array creates energy presents for the raise converter; the transfer of the raise converter is labored via MPPT algorithm to such an extent that maximum intense benefits from solar oriented PV show off is upgraded

and moreover offers easy execution of BLDC engine for pumping application. The foyer sensors are utilized as part of request to come across rotor role of engine. Hall sensors are electronically pushed circuit applied for inverter changing.

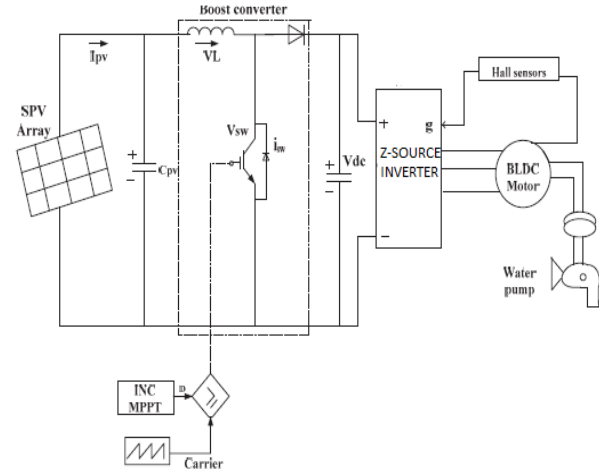


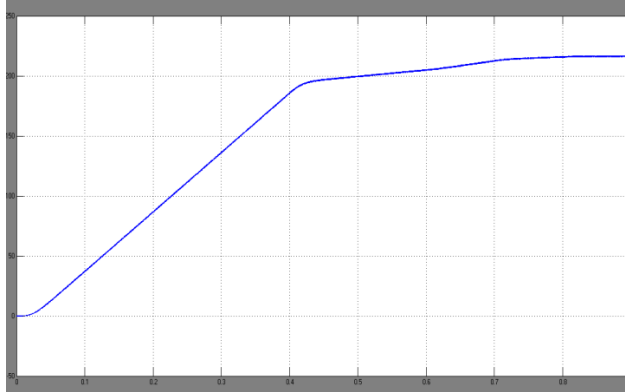
Fig:2 Z-Source Inverter

By using Z-source inverter the motor run at adjustable speed and motor drives between restrictions of Voltage source inverter. In VSI inductor used as voltage enhance the power factor but it appears complications like voltage sag, line harmonics and limited obtainable output voltage. By using Z-source inverter the above mentioned problems overcome. In Z-source inverter inductor, capacitor values are calculated. The z-source inverter functions as either voltage source or current source. It can be function as Buck-Boost converter. Thus it can give the converted yield voltage. Its unwavering quality is high because of lower EMI commotion and harmonics. The ZSI can take a shot at stack either be Inductive, Capacitive or Z-source arrange. The shifted working strides of the setup regarded in Fig.2 as an instance the SPV array, the carry converter along the water pump are planned with the stop intention that a sensible capability is consistently capable below some kind of change in solar powered insolation degree. A BLDC engine of 1.3 kW appraised manipulate is desired alongside each phase of the proposed framework are do not forget in like way as take after.

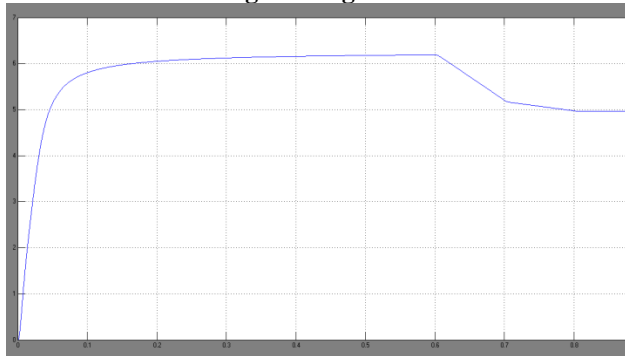
### VI. SIMULATED PERFORMANCE OF THE PROPOSED SYSTEM:

Execution of the reproduced framework is tested as follows. The proposed framework is recreated in MATLAB; following results are were given, as confirmed as follows. The proposed framework

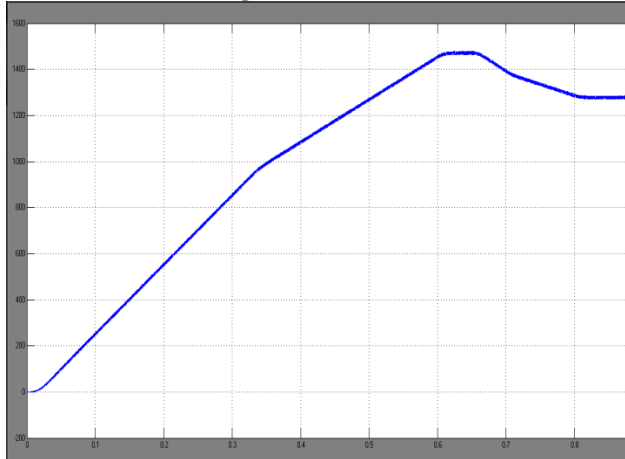
consist output of sun orientated PV array, inverter, converter and BLDC motor pumping yield. Each region comes about is extricated from proposed framework through utilizing MATLAB/Simulink. The simulated comes approximately are confirmed as follows.



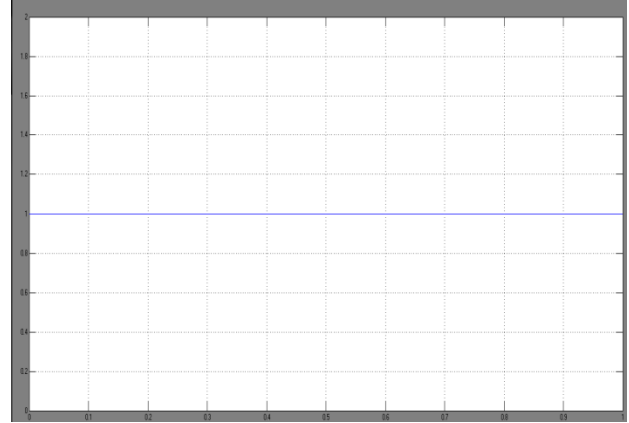
**Fig. 3 voltage**



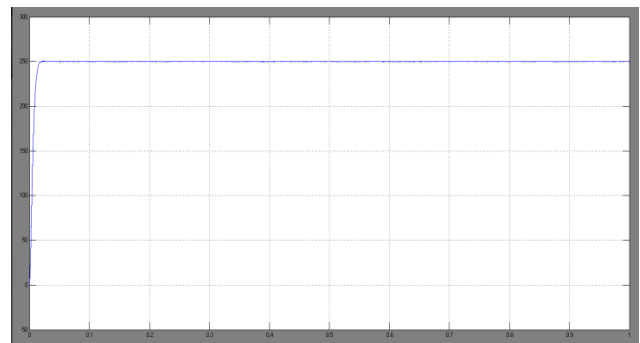
**Fig. 4 current**



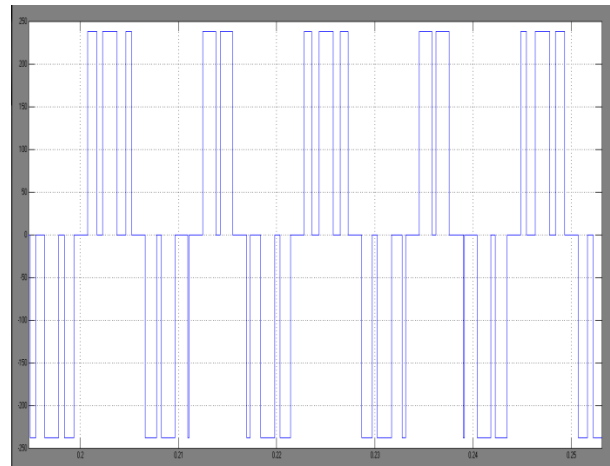
**Fig. 5. Power**



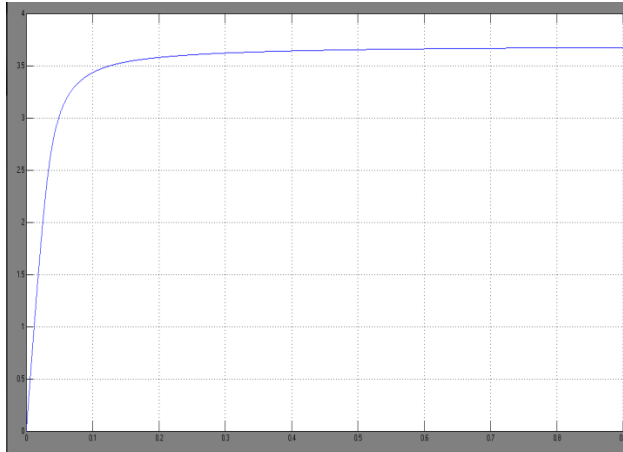
**Fig.6 Insolation**



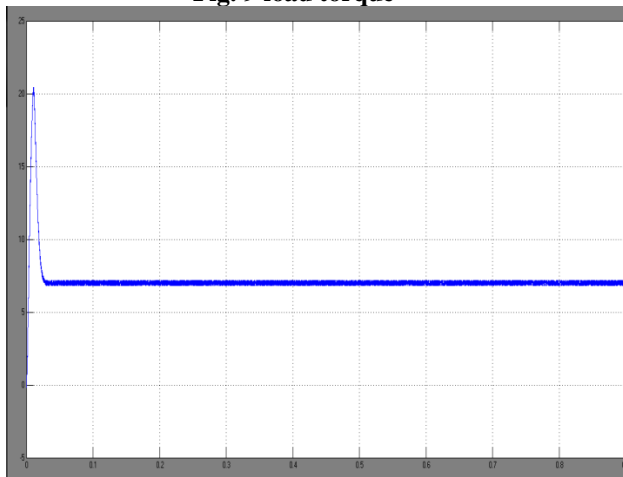
**Fig.7 show that converter output of the system**



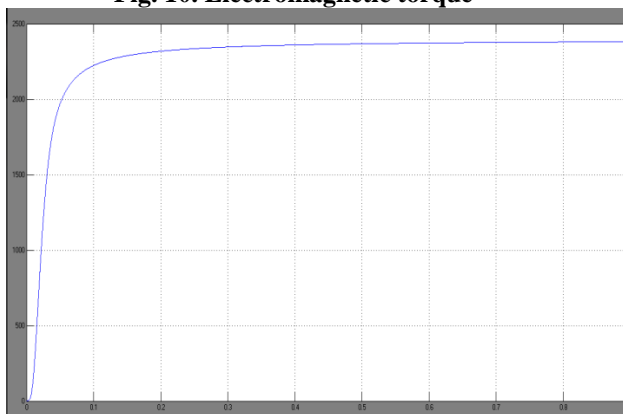
**Fig. 8 Show that inverter output of the system**



**Fig. 9 load torque**

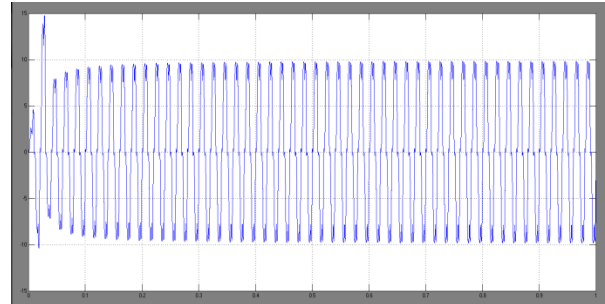


**Fig. 10. Electromagnetic torque**

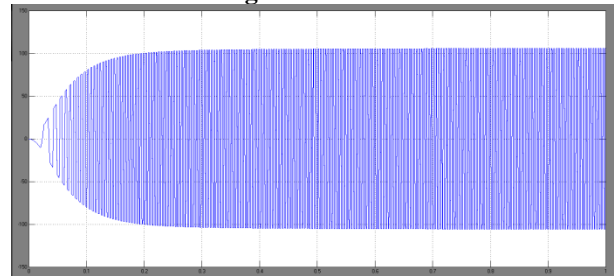


**Fig. 11 Speed**

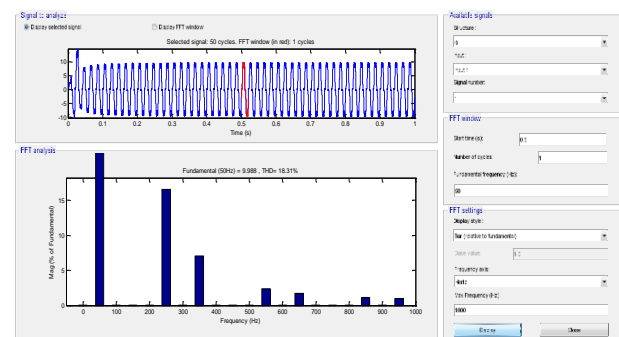
Fig 8 show the stator currents by the side of with the smooth speed, N. The motor is drawing the rated current and its rated speed, ensuing in the water pumping with filled load capacity. The above all results are gives idea when solar system used for pumping application.



**Fig.12current**

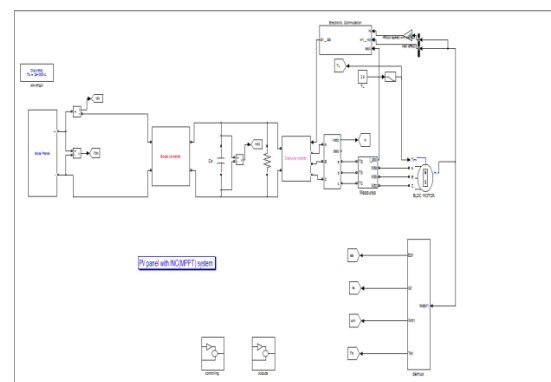


**Fig.13 show stator back EMF of BLDC motor.**

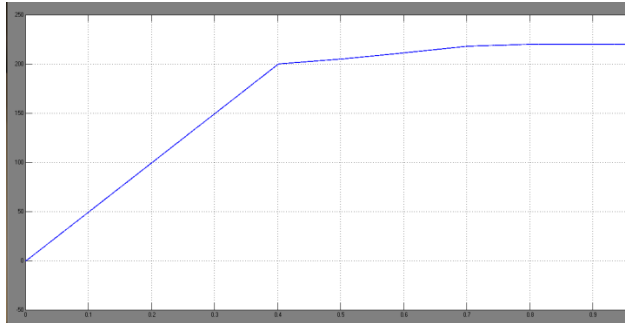


**Fig14. Current THD**

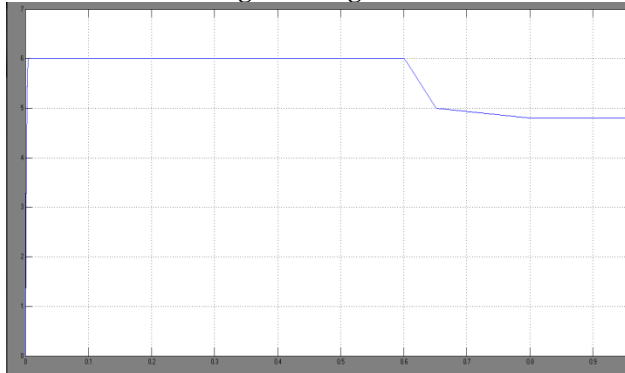
### **SIMULATION RESULTS USING Z-SOURCE INVERTER:**



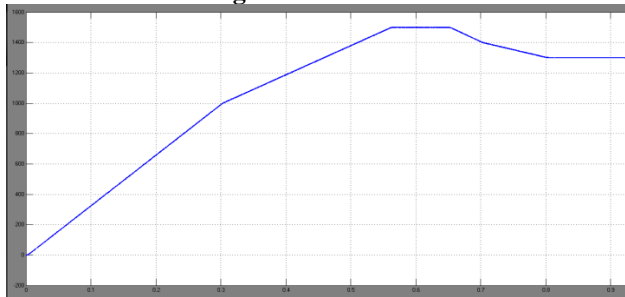
**Fig. 15Block diagram of MAT lab-Simulation Results in Brush loss Direct Current Motor.**



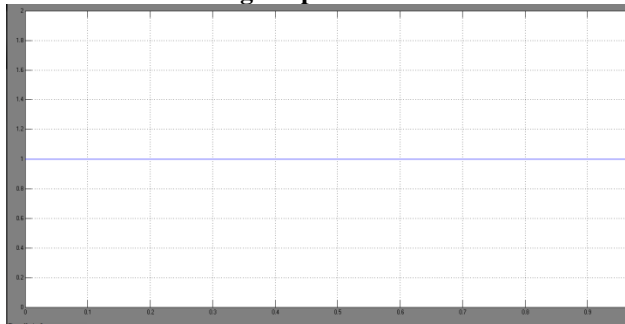
**Fig. 16** voltage



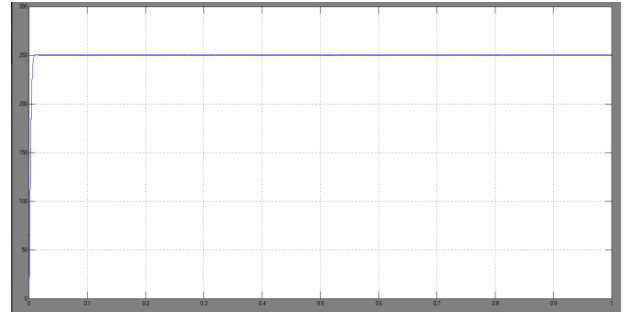
**Fig. 17** current



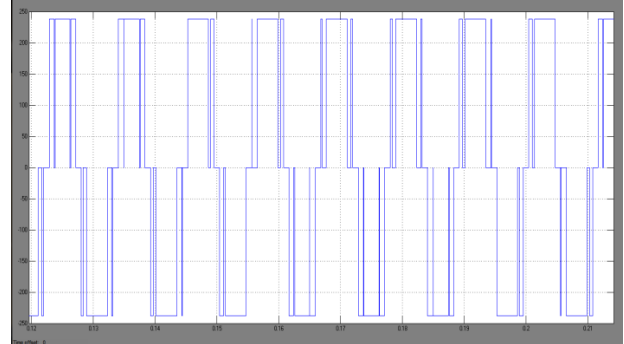
**Fig. 18** power



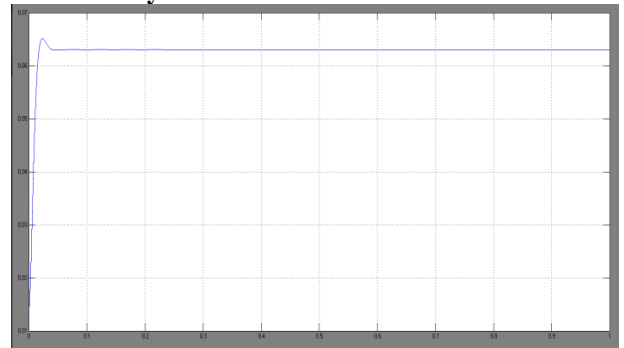
**Fig.19** SPV array variables consisting of insolation



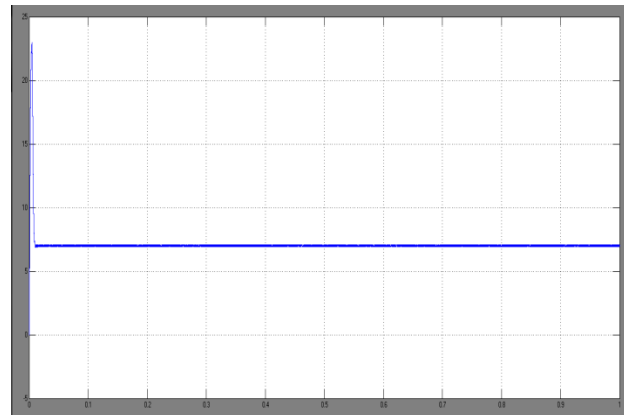
**Fig. 20** show that converter output of the system



**Fig. 21 (a) and (b)** Show that inverter output of the system with different simulation



**Fig. 22** Load torque



**Fig. 23** Electromagnetic torque

PARAMETER	VSI	Z-source
CURRENT THD	18.3%	12.11%

Fig. 24 Current THD

Table.2. FFT Analysis

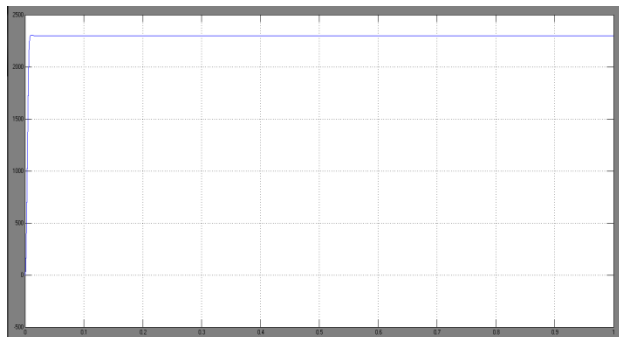


Fig.24Speed

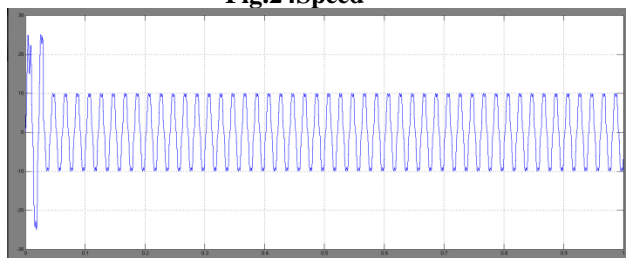


Fig. 25 current

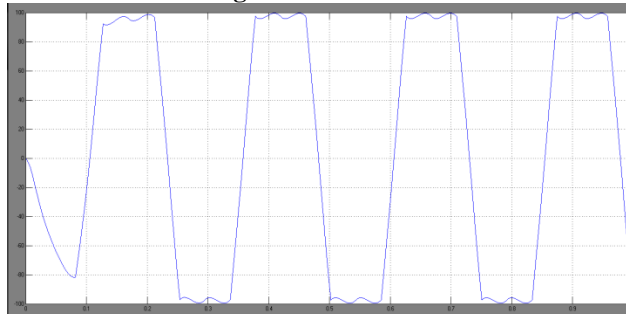
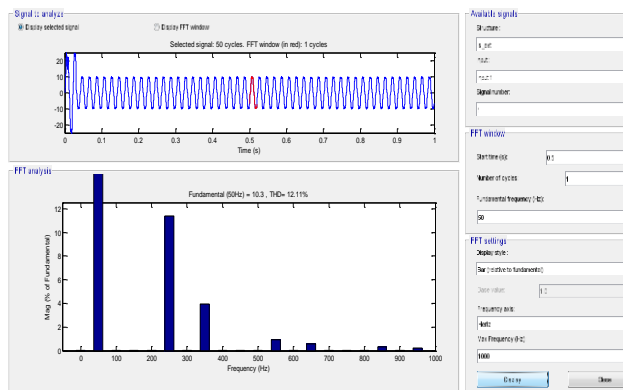


Fig. 26emf



The above TABLE Explains about difference between VSI and Z-source inverter. The Z-source inverter gives best results compare to VSI.

**VII.CONCULSION:-**

By mistreating adequate progressive conductance, the DC-DC boost gadget provides dependable saddler as well as cost-effectiveness from the SPV panel. The MPPT algorithmic rule is half-tracked correctly. The MPPT tracking, in combination with the bit drop that is sent to the inverter, provides a precise result to the inverter, which is subsequently fed to the BLDC motor. The proposed system has a BLDC motor with a swish and soft solar rating. The proposed technology, which uses a centrifugal pump as a load, provides BLDC Motors with swish speed and power.

**VII.REFERENCE:-**

[1] SatarupaBal, Student Member, IEEE and B. ChittiBabu, Member, IEEE” Comparison of Mathematical Model of photovoltaic Module and effect of various parameters on its performance”978-1-4673-6150-7/13/2013IEEE

[2]Rashid, M.h “Power Electronics Handbook: Device, Circuits and Application” (Elsevier inc., oxford, UK, 2011, 3rd edn.)

[3]Bhim Singh, Rajan Kumar “Simple Brushless DC Motor Drive for Solar Photovoltaic Exhibit Fed Water Pumping System” IET Power Electron. 2016, vol. 9, iss. 7, pp. 1487–1495

[4]Kumar, r., Singh, b., Chandra, a., et al.: “Solar PV Exhibit Fed Water Pumping Using BLDC Motor Drive With Boost–Buck Converter”. IEEE energy conversion congress and exposition (ecce), 20–24 September 2015, pp. 5741–5748

[5]Faraji, r., rouholamini, a., naji, h.r., et al.:“Fpga-Based Real Time Incremental Conductance Maximum Power Point Tracking Controller for Photovoltaic Systems”, IET Power Electron. 2014, 7, (5), pp. 1294–1304.



[6]Fangrui, L., et al., A Variable Step Size INC MPPT Method for PV Systems, IEEE Trans. on Industrial Electronics, 2008, Vol.55, No. 7, p.p. 2622-2628

[7]Non- conventional energy resources” (2th edition, 2010) by B H Khan

[8]Mohan, N., Undeland, T.M., Robbins, W.P.: ‘Power electronics: converters, applications and design’ (John Wiley & Sons Inc., New Delhi, India, 2009, 3rd edn.).